

NAILING FIN INSTALLATION METHOD

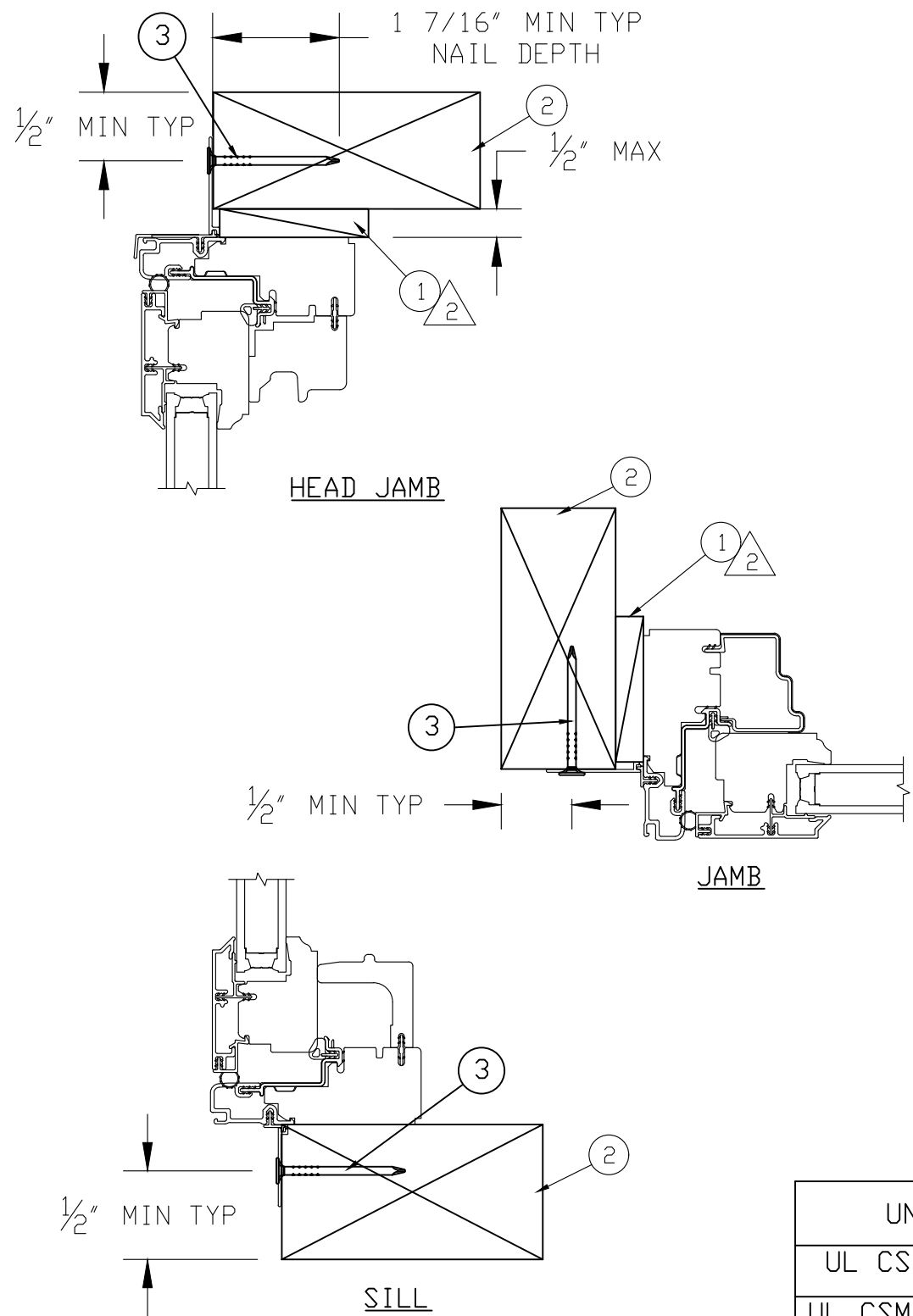

NARROW FRAME PRODUCT DETAILS

- NOTES FOR ALL METHODS:
- THIS PRINT IS FOR STRUCTURAL PERFORMANCE ONLY. FOR FLASHING & SEALING INSTRUCTIONS, REFER TO THE INSTALLATION INSTRUCTIONS.
 - SHIMS
-PLACE A SHIM WITHIN 4-6 INCHES OF EACH CORNER AND SPACE ALL OTHERS EVENLY A MAXIMUM OF 15" APART.
 - IF CHEMICALLY TREATED LUMBER IS USED FOR BUCK MATERIAL, FASTENERS INTO THE BUCK MUST BE A MINIMUM OF 0.90 OZ/FT² ZINC HOT DIPPED GALVANIZED OR STAINLESS STEEL TYPE 304 OR 316.

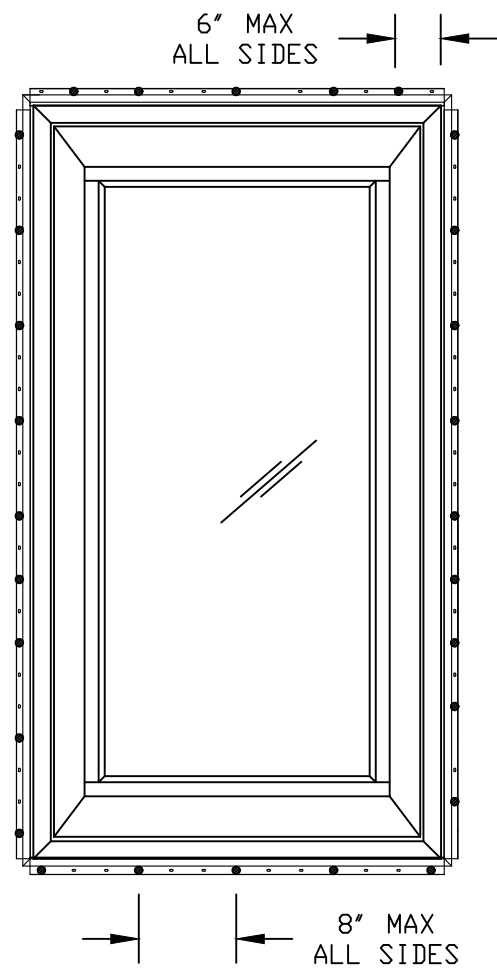

- NAILING FIN INSTALLATION METHOD:**
- UNIT MUST NOT BE IN DIRECT CONTACT WITH EITHER CONCRETE OR TREATED BUCK MATERIAL. IF SHIM SPACE IS LESS THAN 1/8" WRAPPING THE UNIT ON ALL 4 SIDES WITH WINDOW FLASHING TAPE IS REQUIRED AS A BARRIER BETWEEN THE UNIT AND CONCRETE OR TREATED LUMBER.
 - #8 X 1 1/4" PAN HEAD OR WAFER HEAD SCREWS MAY BE SUBSTITUTED FOR 1 1/2" ROOFING NAILS.

UNIT	MAX FRAME SIZE	DP RATING
UL CSMNT PD	36 X 71 1/8	+50/-50
UL CSMNT NFPO	36 X 71 1/8	+50/-50

ITEM NO	REF NO	DESCRIPTION
3	-----	1 1/2" ROOFING NAIL
2	-----	WOOD BUCK BY OTHERS
1	-----	SHIM

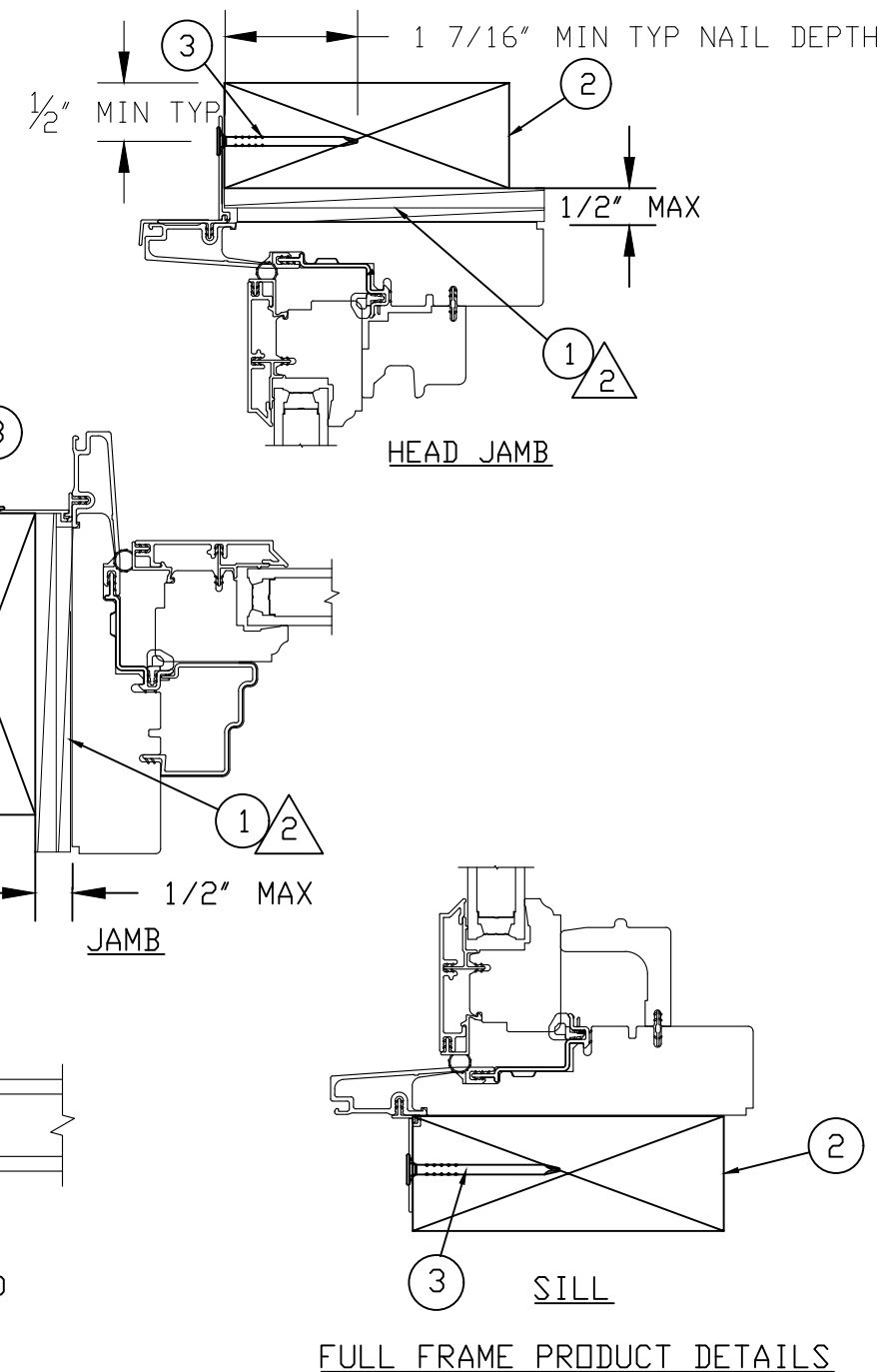

UNSPECIFIED TOLERANCES	
DECIMALS: XX ± .03 XXX ± .012	ANGLE DEG: ± .5
LINEAL: + .125 - .000	FAB LINEAL: ± N/A
MATERIAL: N/A	

MARVIN RESEARCH & DEVELOPMENT	
PRODUCT: ULTIMATE CASEMENT	
CATEGORY:	
UNIT TYPE: UCAPO, UCANFPO	
DWG TYPE: INSTALLATION	
DESCRIPTION: INSTALLATION	
CHK:	SIZE: B
APP:	SCALE: NA
CLASS:	DATE: 10/21/09
DWG NO: 00114252	DWG BY: BRUCE, KEVIN
SHEET: 1 OF 1	

NOTICE - CONFIDENTIAL INFORMATION

The information in this document is privileged and strictly confidential. The information contained herein shall be used only by Marvin Windows and Doors employees and by those agents or suppliers granted official written permission. If the reader of this document is not the intended recipient, or the employee or agent of the intended recipient, please delete this document from all data storage devices, and destroy all hard copies. Any unauthorized dissemination, distribution, copying or other use of the information contained in this document is strictly prohibited.